

Classic

User Manual

Monroe Classic Setting the Pace for the Future

Your Monroe Classic was built with the highest standards of quality and workmanship. Because we have over nine decades of experience in the design and manufacture of fine office equipment, you have a product you can rely upon. Quality...Performance...Value... in calculators for you or your Company.

Monroe Classic Calculators are backed by a comprehensive warranty that covers parts and labor. And that same comprehensive protection, and convenient service, can be extended for as long as you own your calculator. The Monroe Maintenance Agreement is renewable annually at your option.

At Monroe, service is not just a slogan, it's a promise from the company that has made customer service its top priority. When you need us, we respond.

Contents:

Operating Controls and Features.....	2
Applications.....	4
General Information.....	20
Ordering supplies.....	21

About Your Monroe Classic

Our new Monroe Classic will give you the opportunity to solve a variety of figurework problems more accurately and efficiently than ever before. This instruction book will help you by providing complete, step-by-step information on the operation and application of your Monroe Classic. Whether you're an experienced operator or a beginner, you'll gain a practical, working knowledge of your Monroe Classic after reading this book.

We want to be sure you take advantage of the many benefits Monroe value has to offer. If you have any questions about a particular feature or application, don't hesitate to call 888-666-7631.

Monroe Classic

Serial Number:

Please record the Serial Number of your new calculator in the space provided above and retain this instruction booklet for your records and future reference. The Serial Number is located on the bottom case cover of your calculator.

Thank you,

Monroe Systems for Business



WARNING

NOTE: This equipment has been tested and found to comply with the limits for a Class B digital device, pursuant to Part 15 of the FCC Rules. These limits are designed to provide reasonable protection against harmful interference in a residential installation. This equipment generates, uses and can radiate frequency energy and, if not installed and used in accordance with the instructions, may cause harmful interference to radio communications. However, there is no guarantee that interference will not occur in a particular installation. If this equipment does cause harmful interference to radio or television reception, which can be determined by turning the equipment off and on, the user is encouraged to try to correct the interference by one or more of the following measures:

- Reorient or relocate the receiving antenna.
- Increase the separation between the equipment and receiver.
- Connect the equipment into an outlet on a circuit different from that to which the receiver is connected.
- Consult an experienced radio/TV technician for help.

If necessary, the user should consult Monroe or an experienced radio/television technician for additional suggestions.

16. Non-Add/Date Key. This key serves three functions. First, it will print a live entry as an identifier (such as an invoice number) or a date. Second, it will store a live entry so that it may be recalled for later use as an identifier or constant. Third, when the D PD N selector switch is in the D (display only position) press #/Date to override the display only setting to print an intermediate sequential calculation result.

To print and store a date (e.g., 7/1/01), enter the month and depress the Decimal Point key, the date and Decimal Point, and the year and depress the Non-Add/Date key. To recall the contents of the Non-Add Register, depress the Non-Add/Date key.

17. Grand Total Lamp. When illuminated, indicates that an amount is being retained in the Grand Total Accumulator.

18. Accumulator Lamp. When illuminated, indicates that an amount is being retained in the Accumulator.

19. Memory One Plus Key. Adds an amount to Memory. If there is a live calculation pending, the Memory Plus key will complete the calculation and accumulate the result to Memory.

20. Memory One Minus Key. Subtracts an amount from Memory. If there is a live calculation pending, the Memory Minus key will complete the calculation and subtract the amount from Memory.

21. Memory One Subtotal Key. Prints but does not clear the Memory.

22. Memory One Total Key. Prints and clears the Memory.

23. Memory Two Plus Key. Adds entries directly into Memory. This key will also complete pending calculations and accumulate the results to Memory.

24. Memory Two Minus Key. Subtracts entries directly from Memory. This key will also complete pending calculations and subtract the results from Memory.

25. Memory Two Subtotal Key Prints but does not clear Memory.

26. Memory Two Total Key. Prints and clears the Memory.

27. Set Up Key. This unique key enables the operator to select internal functions. To turn a function on, the operator presses the Set Up key followed by a numeric code entry at which point the code number will print in black. To turn a function off, the operator presses the Set Up key followed again by the numeric code at which point the code number will print in red.

Set Up Key Codes

- 0: Sets calculator to Price/Price mode when decimal selector at +.
- 00: Sets calculator to Units/Units mode when decimal selector at +.
- 1: ΣX , Summation of first factors in Memory One.
- 2: ΣT , Summation of Equals and Percent results into the accumulator.

- 3: Running subtotal of the accumulator on printer.
- 4: Two-column Addition.
- 5: Set rounding to TRUNCATE.
- 6: Set rounding to ROUND UP.
- 7: Set IDENTIFIER to print for each entry.
- 8: ΣM , Summation of Equals and Percent results into Memory One.
- 9: Recall Set Up Codes.
- C/CE: Clear all Set Up Codes
- +: Definable Add Mode
- : Nickel Rounding
- ▲: Paper Saver Mode
- #/Date Date/Time Clock
- * Cross foot, % Dist., Prorate
- ◇ Basic Financial Functionality

If both Set Up Code 0 and Set Up Code 00 are ON, the calculator will be set to Price/Units mode when decimal selector is at +.

28. Percent Change/Gross Margin Key.

Automatically compares any two amounts, prints the actual numerical difference between them, then calculates and prints the percent change or the gross margin percentage.

29. Tax. This key serves two functions. First, it stores a live entry as the tax rate. Second, it will automatically compute the amount of tax and amount of increase if pressed when no live entry exists. For computation of decrease and net, press following depression of the \div key.

30. Markup. From a known cost of goods and desired gross margin, this key automatically calculates and prints the amount of Markup and the selling price.

31. Backspace Key. Deletes right most character of a live entry, moving the remaining display value one character to the right.

32. Paper Advance.

On-Off Switch. Located on the side of the calculator.

Decimal System. With the Classic, entries may contain any combination of whole and decimal digits, up to a maximum of 12 digits. However, internally there is a 24-digit calculating capability.

Add Mode. Set the Decimal Selector at Add Mode (+) and the last two digits in any entry followed by depression of the Plus, Minus, Memory Plus or Memory Minus key will automatically be accepted as decimals. Exception: if an actual decimal entry is made, the calculator will accept and print it, overriding the Add Mode (+) setting for that entry.

Units/Price Mode. Designed for convenience when calculating extensions. With the decimal selector at Add Mode (+), all numbers entered followed by depression of the Times key will be accepted as whole numbers (units) unless an actual decimal entry is made. The last number entered followed by depression of the Equals, Equals Plus or Equals Minus key will automatically be accepted as having two decimal places (dollars and cents). Memory Plus/Memory Minus will function in the same manner when completing calculations.

Automatic Punctuation. On the tape and display a comma automatically punctuates every third whole digit to the left of the decimal point.

Extended Capacity. If a result exceeds the 12-digit output capacity but does not exceed the 24-digit calculating capacity, then the result will be printed and displayed in scientific notation.

For example: if a calculation result was "222,333,444,555,000." it would be expressed in scientific notation as "2.22333444555 x 10¹⁴." The printer would print the amount as "2.2233344455514," which indicates that to write the extended capacity amount in standard format, the decimal point must be moved 14 digits to the right.

NOTE: On the Classic, the printer will show 12 significant digits and the exponent, while the display will show 9.

Overflow. When a live entry contains more than 12 digits (display and print capacity) or a calculation result contains more than 24 digits (calculating capacity), a series of red commas will print indicating an overflow condition. The display will show a "0". The entry and/or result is automatically cleared and the calculator is ready for further calculations. Constants and N Counts are not affected by this overflow condition.

Underflow. In a result or total containing a combination of whole and decimal digits, the decimal point will shift right, regardless of decimal setting in order to show the 12 most significant digits. In results containing more than 12 whole digits the calculator will go into extended capacity.

Reverse Underflow. When a result should normally be 0, based on the current decimal setting, the calculator will float the result showing as many digits as possible. For example, the problem 2 divided by 625, with the Decimal Selector set at (2), would yield a result 0.00 without Reverse Underflow. With this feature, however, a significant result of 0.0032 is given.

Automatic Calculation Mode Correction. If you accidentally depress the Times key instead of the Divide key (or vice-versa), it is not necessary to clear the calculator. Merely depress the correct function key (in this case, the Divide key) and proceed with the calculation.

Two Key Rollover. Allows an operator to depress a numeric or function key while the previous key is depressed or being released.

Clear Accumulator Indicator. If the Accumulator contains the value zero, a unique symbol (*) prints with the first entry into Accumulator.

Square Root. The key sequence Divide, Equals will automatically calculate the square root of any positive entry, result or total.

Applications

Unless otherwise specified the following examples are performed with D PD N @ PD and \diamond ■ GT @ ■.

Addition Result Multiplied by a Number
Decimal Selector @ +
Example: $(2.77 + 14.98 + 3) \times 12.12 = 251.49$

Enter	Depress	Print
	*	0.00 *
277	+	2.77 * +
1498	+	14.98 +
3.	+	3.00 +
	*	20.75 *
	X	20.75 X
1212	=	12.12 =
		251.49 *

Group and Grand Total with N Count
D PD N @ N, \diamond ■GT @ GT
Decimal Selector @ +
Example:

1.23		1.59
+1.23		-3.57
-4.56		+12.50
+7.89		5.79
		10.52
	N Count = 4	N Count = 3
	5.79 + 10.52 = 16.31	Grand Total
	4 + 3 = 7	Grand Total N Count

Enter	Depress	Print
	*	000
	*	0.00 *
123	+	1.23 * +
	+	1.23 +
456	-	4.56 -
789	+	7.89 +
	*	004
		5.79 *
159	+	1.59 * +
357	-	3.57 -
1250	+	12.50 +
	*	003
		10.52 *
	*	007
		16.31 G *

Addition and Subtraction with N Count to Figure Average
D PD N @ N
Decimal Selector @ +
Example:

2.00		
+0.95		
+0.00		N Count = 5
-0.50		Average = 0.34
-0.75		
1.70		

Enter	Depress	Print
	*	000
		0.00 *
200	+	2.00 * +
95	+	0.95 +
0	+	0.00 +
50	-	0.50 -
75	-	0.75 -
	*	005
		1.70 *
	=	0.34 = M

Chain Multiplication
Decimal Selector @ 2
Example: $12.3 \times 4.2 \times 2.5 = 129.15$

Enter	Depress	Print
12.3	x	12.30 x
4.2	x	4.20 x
2.5	=	2.50 =
		129.15 *

Constant Multiplication
Decimal Selector @ 2
Example: $1.65 \times 211 = 348.15$
 $1.65 \times 59 = 97.35$
 $1.65 \times 67 = 110.55$

Enter	Depress	Print
1.65	x	1.65 x
211	=	211.00 =
		348.15 *
59	=	59.00 =
		97.35 *
67	=	67.00 =
		110.55 *

Simple Multiplication
Decimal Selector @ 2
Example: $12.3 \times 15 = 184.50$

Enter	Depress	Print
12.3	x	12.30 x
15	=	15.00 =
		184.50 *

Applications

Units/Price Mode

Decimal Selector @ +

Example: $6 \times 6.47 = 38.82$
 $8 \times 1.19 = 9.52$

Enter	Depress	Print
6	x	6.00 x
647	=	6.47 =
		38.82 *
8	x	8.00 x
119	=	1.19 =
		9.52 *

Accumulative Multiplication

Decimal Selector @ +

Example: $(23.5 \times 10.18) = 239.23$
 $-(4.6 \times 9.75) = 44.85$
194.38

Enter	Depress	Print
	*	0.00 *
23.5	x	23.50 x
1018	=+	10.18 =+
		239.23 **
4.6	x	4.60 x
975	=-	9.75 =-
		44.85 *
	*	194.38 *

Accumulative Multiplication with Group and Grand Total with N Count

D PD N @ N, ◇ ■GT @ GT

Decimal Selector @ +

Example: $(10 \times 1.50) = 15.00$
 $+ (12 \times 1.75) = + 21.00$
 $+ (12 \times 1.25) = +15.00$
- (12 \times 1.15) = 13.80

37.20

N Count = 4

$(100 \times 1.25) = 125.00$
- (5 \times 7.50) = -37.50

87.50

N Count = 2

$37.20 + 87.50 = 124.70$ Grand Total

$4 + 2 = 6$ Grand Total N Count

Enter	Depress	Print
	* 000	0.00 *
	* 000	0.00 G *
10	x	10.00 x
150	=+	1.50 =+
		15.00 **
12	x	12.00 x
175	=+	1.75 =+
		21.00 *
125	=+	1.25 =+
		15.00 *
115	=-	1.15 =-
		13.80 *
	* 004	37.20 *
100	x	100.00 x
125	=+	1.25 =+
		125.00 **
5	x	5.00 x
750	=-	7.50 =-
		37.50 *
	* 002	87.50 *
	* 006	124.70 G *

Applications

Simple Division

Decimal Selector @ 2

Example: $375 \div 500 = 0.75$

Enter	Depress	Print
375	\div	375.00 \div
500	=	500.00 =
		0.75 *

Percent of Number

Decimal selector @ 2

Example: What is 16% of 150?

Enter	Depress	Print
150	x	150.00 x
16	%	16.00 %
		24.00 *

Constant Division

Decimal Selector @ 2

Example: $48 \div 3 = 16.00$
 $12 \div 3 = 4.00$
 $10.5 \div 3 = 3.50$

Enter	Depress	Print
48	\div	48.00 \div
3	=	3.00 =
		16.00 *
12	=	12.00 =
		4.00 *
10.5	=	10.50 =
		3.50 *

Different Percents Of a Number

Decimal selector @ 2

Example: What is 16%, 25%, 18%, 42% of 150?

Enter	Depress	Print
150	x	150.00 x
16	%	16.00 %
		24.00*
25	%	25.00 %
		37.50 *
18	%	18.00 %
		27.00 *
42	%	42.00 %
		63.00 *

Accumulative Division

Decimal Selector @ 2

Example: $(1493 \div 11.73) = 127.28$
 $-(392 \div 5.55) = -70.63$
56.65

Enter	Depress	Print
	*	0.00 *
1493	\div	1,493.00 \div
11.73	=+	11.73 = +
		127.28 **
392	\div	392.00 \div
5.55	=-	5.55 = -
		70.63 *
	*	56.65 *

Percent of One Number To Another

Decimal selector @ 2

Example: What percent of 150 is 60?

Enter	Depress	Print
60	\div	60.00 \div
150	%	150.00 =
		40.00 %

Applications

Percent of One Number To Different Numbers

Decimal selector @ 2

Example: What percent of 150 is 60, 30, 50, 75?

Enter	Depress	Print
60	÷	60.00 ÷
150	%	150.00 =
		40.00 %
30	%	30.00 =
		20.00 %
50	%	50.00 =
		33.33 %
75	%	75.00 =
		50.00 %

Discount

Decimal Selector @ 2

Example: What is the amount of discount and the cost of an article marked \$28.40 less 12.5%?

Enter	Depress	Print
28.4	x	28.40 x
12.5	%	12.50 %
		3.55 * (Discount)
	-	24.85 %- (Cost)

Add-on

Decimal Selector @ 2

Example: What is the tax and the total cost of an article marked \$24.25? Tax is 4%.

Enter	Depress	Print
24.25	x	24.25 x
4	%	4.00 %
		0.97 * (Tax)
	+	25.22 %+ (Total Cost)

Chain Discount

Decimal Selector @ +

Example: What is the net amount and the amount of discount, given \$125.50 less a chain discount of 10%, 5%, 2%?

Enter	Depress	Print
	*	0.00 *
12550	+	125.50 * +
	x	125.50 x (Gross)
10	%	10.00 %
		12.55 * (Discount)
	-	112.95 % -
	x	112.95 x
5	%	5.00 %
		5.65 * (Discount)
	-	107.30 % -
	x	107.30 x
2	%	2.00 %
		2.15 * (Discount)
	-	105.15% - (Net)
	-	105.15 -
	*	20.35 * (Total Disc)

N Count Correction Operations, Incorrect amount entered on + key

Decimal Selector set @ +

D PD N @ N

Example:

20.00
 + 30.00 Number of correct entries = 4
 +40.00 Average = 35.00
~~+60.00~~
 +50.00
 140.00

Enter	Depress	Print
	* 000	0.00 *
2000	+	20.00 * +
3000	+	30.00 +
4000	+	40.00 +
(Wrong Entry) 6000	+	60.00 +
(Correction)	-	60.00 -
(Valid Entry) 5000	+	50.00 +
	* 004	
	=	140.00 *
		35.00 = M

Applications

Incorrect Amount Entered on =+ =-, for accumulation to the Adding Register.

Decimal Selector set @ +

D PD N @ N

Example:

12.00 x	1.19 =+	1.15 =+	13.80
4.00 x	4.56 =-	1.23 =-	4.92
		Subtotal	8.88
56.00 ÷	13.00 =+	12.00 =+	4.67
			13.55

Correct N-Count=3 Average = 4.52

	Enter	Depress	Print	
		* 000	0.00	*
	12	x	12.00	x
(Wrong Entry)	119	=+	1.19	=+
			14.28	**
(Correction)		-	14.28	-
(Valid Entry)	115	=+	1.15	=+
			13.80	* *
	4	x	4.00	x
(Wrong Entry)	456	=-	4.56	=-
			18.24	*
(Correction)		+	18.24	+
(Valid Entry)	123	=-	1.23	=-
			4.92	*
		◇ 002	8.88	◇
	56	÷	56.00	÷
(Wrong Entry)	13.	=+	13.00	=+
			4.31	*
(Correction)		-	4.31	-
	56	÷	56.00	÷
(Valid Entry)	12.	=+	12.00	=+
			4.67	*
		* 003	13.55	*
		=	4.52	=M

Memory Addition and Subtraction

Decimal Selector @ +

Example:

25.76	+ 9.48
	+ 9.48
	- 2.71
	- 2.71
	+ 8.85
	48.15

Enter	Depress	Print
	I *	0.00 I *
2576	I+	25.76 I+
948	I+	9.48 I+
	I+	9.48 I+
271	I-	2.71 I-
	I-	2.71 I-
885	I+	8.85 I+
	I*	48.15 I*

Accumulative Multiplication to Memory

Decimal Selector @ 2

Example:

(23.5 x 10.18)		239.23
-(4.6 x 9.75)		44.85
		194.38

Enter	Depress	Print
	I *	0.00 I *
23.5	x	23.50 x
10.18	I+	10.18 =
		239.23 I+
4.6	x	4.60 x
9.75	I-	9.75 =
		44.85 I-
	I *	194.38 I *

Applications

Accumulative Division to Memory

Decimal Selector @ 2

Example: $(1493 \div 11.73) = 127.28$
 $-(392 \div 5.55) = 70.63$
56.65

Enter	Depress	Print
	I *	0.00 I *
1493	÷	1,493.00 ÷
11.73	I +	11.73 =
		127.28 I+
392	÷	392.00 ÷
5.55	I-	5.55 =
		70.63 I -
	I*	56.65 I*

Proration

Decimal selector @ 2

Example: Find the floor rental expense for each department

Dept	Floor Space Square Feet	Rental Expense
A	875	\$2,053.96
B	1,480	3,474.13
C	<u>1,375</u>	<u>3,227.65</u>
	3,730	\$8,755.74

Enter	Depress	Print
	*	0.00 *
8755.74	÷	8,755.74 ÷
875	+	875.00 * +
1480	+	1,480.00 +
1375	+	1,375.00 +
	*	3,730.00 *
	x	3,730.00 ☒
875	=+	875.00 = +
		2,053.96 **
1480	=+	1,480.00 = +
		3,474.13 *
1375	=+	1,375.00 = +
		3,227.65 *
	*	8,755.74 *

Percentage Distribution

Decimal selector @ 2

Example:

City	Sales In Thousands	Percent of Sales
A	\$ 123	8.99%
B	456	33.33
C	<u>789</u>	<u>57.68</u>
	\$1,368	100.00%

Enter	Depress	Print
	*	0.00 *
123	+	123.00 * +
	÷	123.00 ÷
456	+	456.00 +
789	+	789.00 +
	*	1,368.00 *
	%	1,368.00 =
		8.99%
	+	8.99 * +
456	%	456.00 =
		33.33%
	+	33.33 +
789	%	789.00 =
		57.68%
	+	57.68 +
	*	100.00 *

Applications

Invoicing

Decimal selector @ +

Example: Date 9/6/99
 Invoice #00125
 48 Cases @ \$1.23 per case = \$ 59.04
 54 Cases @ \$4.32 per case = 233.28
 33 Cases @ \$5.22 per case 172.26
 \$464.58
 Less 12% Discount 55.75
 Tax 6% -24.53
 Shipping Charge +15.88
 Return Credit 7.39
 \$441.85

Enter	Depress	Print
	*	0.00 *
9.6.99	# DATE	9 6 99
.00125	# DATE	#00125
48	x	48.00 x
123	=+	1.23 = +
		59.04 **
54	x	54.00 x
432	=+	4.32 = +
		233.28 *
33	x	33.00 x
522	=+	5.22 = +
		172.26 *
	*	464.58 *
	x	464.58 x
12	%	12.00 %
		55.75 *
		408.83%-
	x	408.83 x
6	%	6.00 %
		24.53 *
	+	433.36 %+
	+	433.36 *+
1588	+	15.88 +
739	-	7.39 -
	*	441.85 *

Invoicing with Total Quantity

Decimal selector @ 2

Example: Date 9/6/99
 Invoice #00126
 38 Cases @ \$1.25 per case = \$ 47.50
 62 Cases @ \$4.38 per case =271.56
41 Cases @ \$7.32 per case 300.12
 141 Cases \$619.18
 Less 12% Discount 74.30
 Tax 6% +32.69
 Shipping Charge +16.00
 Return Credit - 3.29
 \$590.28

Enter	Depress	Print
	*	0.00 *
	I *	0.00 I *
9.6.99	# DATE	9 6 99
.00126	# DATE	#00126
38	I+	38.00 I+
	x	38.00 x
1.25	=+	1.25 = +
		47.50 **
62	I+	62.00 I+
	x	62.00 x
4.38	=+	4.38 = +
		271.56 *
41	I+	41.00 I+
	x	41.00 x
7.32	=+	7.32 = +
		300.12 *
	I+	141.00 I *
	*	619.18 *
	x	619.18 x
12	%	12.00 %
		74.30 *
	-	544.88 %-
	x	544.88 x
6	%	6.00 %
		32.69 *
	+	577.57 % +
	+	577.57 * +
16	+	16.00 +
3.29	-	3.29 -
	*	590.28 *

Applications

%▲ **Percent Change**

Decimal selector @ 2

What is the amount of change and percent of change from 590,806 to 675,433?

Enter	Depress	Print	
675433	÷	675,433.00	÷
590806	%△	590,806.00	% C
	Amount of Change	84,627.00	△
	Percent of Change	14.32	% △

%▲ **Gross Margin**

What is the profit (Margin) and the Gross Margin of a product that sells for \$133.33 and costs \$100.00?

Decimal selector @ 2

Enter	Depress	Print	
133.33	x	133.33	x
100	% △	100.00	% C
	Profit (Margin)	33.33	G M
	(Gross Margin)	25.00	% M

Percent Change with Constant First Factor

Decimal selector @ 0

Compare the production figures below to the 1999 production output of 15,371 units.

Year	Units		
1996	12,480		
1997	16,267		
1998	13,785		

Enter	Depress	Print	
1999	#/DATE # 1999		
15371	÷	15,371.	
1996	#/DATE # 1996		
12480	%△	12,480.	%C
		2,891.	△
		23.	% △
1997	#/DATE # 1997		
16267	% △	16,267.	%C
	-	896.	△
	-	6.	% △
1998	#/DATE # 1998		
13785	% △	13,785.	%C
		1,586.	△
		12.	%△

Gross Margin with Constant Selling Price

Based on a selling price of \$2,000.00, what are the profit advantages of decreasing the current cost of \$1,500.00 to \$1,450.00? To \$1,365.00? To \$1,295.00?

Decimal selector @ 2

Enter	Depress	Print	
2000	x	2,000.00	x
1500	%△	1,500.00	%C
	Profit (Margin)	500.00	G M
	(Gross Margin)	25.00	% M
1450	%△	1,450.00	% C
	Profit (Margin)	550.00	G M
	(Gross Margin)	27.50	% M
1365	%△	1,365.00	% C
	Profit (Margin)	635.00	G M
	(Gross Margin)	31.75	% M
1295	%△	1,295.00	% C
	Profit (Margin)	705.00	G M
	(Gross Margin)	35.25	% M

Markup

An item costs \$100. A store selling the item uses a 25% gross margin. What is their profit on the item and what will the selling price be?

Decimal selector @ 2

Enter	Depress	Print	
100	x	100.00	x
25	Mu	25.00%	MU
	(Profit)	33.33	MU
	(Selling Price)	133.33	*

Applications

Memory Operation with N Count

Decimal selector @ +

D PD N @ N

Example $(2 \times 1.50) = 3.00$
 $-(2 \times 2.50) = 5.00$
 $+ 6.00$
 $- 7.50$

 $- 3.50$

N Count = 4

Enter	Depress	Print
	I*	000
		0.00 I *
2	x	2.00 x
150	I+	1.50
		3.00 I+
2	x	2.00 x
250	I-	2.50 =
		5.00 I -
600	I+	6.00 I+
750	I-	7.50 I -
	I*	004
		- 3.50 I*

Automatic Percent Decrease (Discount)

Decimal Selector @ 2

Example: Compute the amount of discount and net cost of two articles marked \$75.00 and \$100.00 respectively. Discount rate is 10%.

Enter	Depress	Print
	C/CE	C
10	TAX	10.00R
75	÷	75.00 ÷
	TAX	10.00R
		7.50 -
		67.50% -
100	÷	100.00 ÷
	TAX	10.00R
		10.00 -
		90.00 % -

Automatic Percent Increase (Tax)

Decimal Selector @ 2

Example: Compute the amount of tax and total cost of two articles marked \$25.00 and \$30.00 respectively. Tax is 5%.

Enter	Depress	Print
	C/CE	C
5	TAX	5.00 R
25	X	25.00 X
	TAX	5.00 R
		1.25 +
		26.25 % +
30	X	30.00 X
	TAX	5.00 R
		1.50 +
		31.50 % +

Markup with Constant Gross Margin

(Constant gross margin is stored in Memory)

What is the selling price of items that cost \$23.50, \$45.23, \$10.79 and \$4.50 based on a gross margin of 42%?

Decimal selector @ 2

Enter	Depress	Print
	I*	0.00 I *
42	I+	42.00 I +
23.50	x	23.50 x
	Mu	42.00 % MU
		(Profit) 17.02 MU
		(Selling Price) 40.52 *
42.53	x	45.23 x
	Mu	42.00% MU
		(Profit) 32.75 MU
		(Selling Price) 77.98 *
10.79	x	10.79 x
	Mu	42.00% MU
		(Profit) 7.81 MU
		(Selling Price) 18.60 *
4.50	x	4.50 x
	Mu	42.00% MU
		(Profit) 3.26 MU
		(Selling Price) 7.76 *
	I*	42.00 I *

Applications

Select Code One Σx

Decimal selector @ 2

Example: Summation of first factors
to Memory

$$\begin{array}{r} (2 \times 3.00) = 6.00 \\ (4 \div 2.00) = \underline{-2.00} \\ 4.00 \\ (3 \div 2.00) = 1.50 \\ \Sigma x = 9 \end{array}$$

Enter	Depress	Print
SET UP		
(Σx Switch ON)	11....
	*	0.00 *
	I *	0.00 I *
2	X	2.00 X
3	=+	3.00 =+
		6.00 **
4	÷	4.00 ÷
2	=-	2.00 =-
		2.00 *
3	=	3.00 =
		1.50 *
	*	4.00 *
	I *	9.00 I *
SET UP		
(Σx Switch OFF)	11....

Select Code One ΣT

Decimal selector @ 2

D PD N @ N, \diamond ■ GT @ GT

Example: Summation of = and %
Results to Accumulator and
GT with N Count

$$\begin{array}{r} 12 \times 5 = 60.00 \\ 45 \times 9 = 405.00 \\ 78 \div 2 = \underline{39.00} \\ \text{N Count} = 3 \quad 504.00 \quad 504.00 \\ 78 \times 5\% = 3.90 \\ 78 \times 4\% = 3.12 \\ 13 \div 90\% = \underline{14.44} \\ \text{N Count} = 3 \quad 21.46 \quad + 21.46 \\ \text{GTN Count} = 6 \quad 525.46 \end{array}$$

Enter	Depress	Print
	*	000
		0.00 *
	*	000
		0.00 G *
SET UP		
(ΣT Switch ON)	22....
12	X	12.00 X
5	=	5.00 =
		60.00 **
45	X	45.00 X
9	=	9.00 =
		405.00 *
78	÷	78.00 ÷
2	=	2.00 =
		39.00 *
	*	003
		504.00 *
78	X	78.00 X
5	%	5.00 %
		3.90 **
4	%	4.00 %
		3.12 *
13	÷	13.00 ÷
90	%	90.00 =
		14.44 %
	*	003
		21.46 *
	*	006
		525.46 G *
SET UP		
(ΣT Switch OFF)	22....

ΣT Count Correction

Incorrect amount summed to the
accumulator \square

Decimal selector @ +

D PD N @ N

Example:

$$\begin{array}{r} 15 \times 0.04 = \del{0.60} \quad 0.40 = 6.00 \\ 78 \div 9.00 = \del{8.67} \quad 6.00 = \underline{13.00} \\ 19.00 \end{array}$$

Enter	Depress	Print
	*	000
		0.00 *
SET UP		
(ΣT Switch ON)	22....
15	X	15.00 X
4	=	0.04 = (Wrong Entry)
		0.60 **
	-	0.60 - (Correction)
.4	=	0.40 =
		6.00 ** (Valid Entry)
78	÷	78.00 ÷
9.	=	9.00 = (Wrong Entry)
		8.67 *
	-	8.67 -
78	÷	78.00 ÷
6.	=	6.00 = (Valid Entry)
		13.00 *
	*	002
		19.00 *
SET UP		
(ΣT Switch OFF)	2	..2..

Applications

Select Code 3
Running Subtotal
Decimal Selector @ +
 D PD N @ N
Example: Entry Balance

	25.76	25.76	
	+ 9.48	35.24	
	+ 9.48	44.72	N Count = 6
	- 2.71	42.01	
	- 2.71	39.30	
	<u>+ 8.85</u>	48.15	
	48.15		

Enter	Depress	Print
	SET UP	
(Running Subtotal ON)	33....
	* 000	0.00 *
2576	+	25.76 * + ◇
948	+	9.48 + ◇
	+	35.24 + ◇
	+	9.48 + ◇
	+	44.72 + ◇
271	-	2.71 - ◇
	-	2.71 - ◇
	-	39.30 + ◇
885	+	8.85 + ◇
	* 006	48.15 * ◇
	48.15	
	SET UP	
(Running Subtotal OFF)	33....

Select Code 4
Two-Column Addition
 Two-Column Addition and Subtraction with N Count
Decimal Selector @ +
 D PD N @ N
Example: Column 1 Column 2

	1.23	1.23	
	-4.56	-4.56	
	+7.89	+7.89	
	+1.25	+1.59	
	<u>+9.87</u>	+5.89	
	15.68	<u>+7.45</u>	
	N Count = 5	19.49	
		N Count = 6	

Enter	Depress	Print
	SET UP	
(TC Switch ON)	44....
	* 000	0.00 *
	* 000	0.00 G *
123	+	1.23 * +
	=+	1.23 G +
456	-	4.56 -
	=-	4.56 G -
789	+	7.89 +
	=+	7.89 G +
159	+	1.59 +
125	=+	1.25 G+
589	+	5.89 +
987	=+	9.87 G +
745	+	7.45 +
	* 006	19.49 *
	* 005	15.68 G*
	15.68	
	SET UP	
(TC Switch OFF)	44....

Applications

Set Up Code 0: Price/Price

Sets calculator to Price/Price mode

Decimal selector @ +

Example: 2.50

$$\begin{array}{r} 2.50 \\ \times 6.55 \\ \hline 16.38 \end{array}$$

$$\begin{array}{r} 17.65 \\ \div 19.00 \\ \hline 0.93 \end{array}$$

Enter	Depress	Print
	SET UP	
	00....
	*	0.00 *
250	x	2.50 x
655	=	6.55 =
		16.38 *
1765	÷	17.65 ÷
1900	=	19.00 =
		0.93 *
	SET UP	
	00....

Set Up Code 0 and 00: Price/Units

Sets calculator to Price/Units mode

Decimal selector @ +

Example 2.50

$$\begin{array}{r} 2.50 \\ \times 655 \\ \hline 1637.50 \end{array}$$

$$\begin{array}{r} 17.65 \\ \div 19.00 \\ \hline 0.01 \end{array}$$

Enter	Depress	Print
	SET UP	
	0	...0...
	SET UP	
	0000....
	*	0.00 *
250	x	2.50 x
655	=	655.00 =
		1,637.50 *
1765	÷	17.65 ÷
1900	=	1,900.00 =
		0.01 *
	SET UP	
	00....
	SET UP	
	0000....

Set Up Code 00: Units/Units

Sets calculator to Units/Units mode

Decimal selector @ +

Example 250

$$\begin{array}{r} 250 \\ \times 655 \\ \hline 163,750.00 \end{array}$$

$$\begin{array}{r} 1765 \\ \div 1900 \\ \hline 0.93 \end{array}$$

Enter	Depress	Print
	SET UP	
	0000....
	*	0.00 *
250	x	250.00 x
655	=	655.00 =
		163,750.00 *
1765	÷	1,765.00 ÷
1900	=	1,900.00 =
		0.93 *
	SET UP	
	0000....

Set Up Code 5: Truncate

Sets Rounding option to Truncation

Decimal selector @ F

Enter	Depress	Print
	SET UP	
	55....
6	÷	6. ÷
	=	6. √
		2.44948974278 *
	SET UP	
	55....

Applications

Set Up Code 6: Round Up

Sets Rounding option to Round Up

Decimal selector @ F

Enter	Depress	Print
	SET UP	
	66....
6	÷	6. ÷
	=	6. √
		2.44948974279 *
	SET UP	
	66....

Set Up Code 7: Set Identifier

Sets numeric Identifier for each entry

Decimal Selector @ +

Example: What is the total for invoices 0123 through 0127. Show invoice number, invoice amount, and product totals.

Invoice #	Amount
0123	1.26
0124	16.73
0125	11.62
0126	- 1.57
0127	<u>5.95</u>
	33.99

Enter	Depress	Print
	SET UP	
	77....
.0123	#/DATE	#0123
126	+	#0123
		1.26 * +
1673	+	#0124
		16.73 +
1126	+	#0125
		11.26 +
	-	#0125
		11.26 -
1162	+	#0125
		11.62 +
157	-	#0126
		1.57 -
595	+	#0127
		5.95 +
	*	33.99 *
	SET UP	
	77....

Set Up Code 8: ΣM, Summation to Memory One

Similar to Set Up Code 2, but the results are summed to Memory One instead of the Accumulator or the GT.

Decimal Selector @ 2

D PD N @ N

Example: Summation of = and % results into Memory One, with N-Count

12 x 5 = 60.00
45 x 9 = 405.00
78 ÷ 2 = 39.00

N-Count = 3 504.00

78 x 5% = 3.90
78 x 4% = 3.12
13 ÷ 90% = 14.44

N-Count = 3 21.46

Enter	Depress	Print
	SET UP	
	88....
	*	000
		0.00 *
	I*	000
		0.00 I *
12	x	12.00 x
5	=	5.00 =
		60.00 * *
45	x	45.00 x
9	=	9.00 =
		405.00 *
78	÷	78.00 ÷
2	=	2.00 =
		39.00 *
	I*	003
		504.00 I *
78	x	78.00 x
5	%	5.00 %
		3.90 * *
4	%	4.00 %
		3.12 *
13	÷	13.00 ÷
90	%	90.00 =
		14.44 %
	I*	003
		21.46 I *
	SET UP	
	88....

Applications

Set Up Code CLEAR, Set Up Code 9

Set Up followed by depression of C/CE key will clear all code settings. Set Up followed by Code 9 will recall and print all Code setting.

Example: Performs the following operations:
Clear all Set-Up Codes.
Turn Set-Up 1 ON
Turn Set-Up Code 2 ON
Recall all Set-Up Codes

Comment	Depress	Print
	SET UP	
Set all codes to OFF	C/CEC
	SET UP	
Code 1 is ON	11....
	SET UP	
Code 2 is ON	22....
	SET UP	
Recall all code settings	9	
.....		
Code 1 is ON	1....
Code 2 is ON	2....
Code 3 is OFF		..3..
Code 4 is OFF		..4..
Code 5 is OFF		..5..
Code 6 is OFF		..6..
Code 7 is OFF		..7..
Code 8 is OFF		..8..
Code 9 is OFF		..9..
Code 0 is OFF		..0..
Code 00 is OFF		..00..
Code + is OFF	+
Code - is OFF	-
Code ▲ is OFF	*

Set Up Code - : Nickel Rounding

Rounds up decimal digits to nearest "nickel" (multiple of 5).

Decimal selector @ 2

Example:

$$\begin{array}{r} 1.11 \\ + 1.11 \\ \hline 2.25 \end{array}$$

Enter	Depress	Print
	SET UP	
	-	***** -
	*	0.00 *
1.11	+	1.11 * +
	+	1.11 +
	*	2.25 *
	SET UP	
	-	***** -

Set Up Code ▲: Paper Saver Mode

Eliminates spacing after totals and results, except of the total (*) key.

Decimal Selector @ 2

Example:

$$\begin{array}{r} 2 \\ + 3 \\ \hline \diamond 5 \\ \times 3 \\ \hline = 15 \\ * 5 \end{array}$$

Enter	Depress	Print
	SET UP	
	▲	***** *
	*	0.00 *
2	+	2.00 * +
3	+	3.00 +
	◇	5.00 ◇
	×	5.00 *
3	=	15.00 *
	*	5.00 *

Set Up Code +: Definable Add Mode

Decimal amounts with fewer or more than 2 decimal places may be added/subtracted without decimal point entry.

Decimal Selector @ 4

Example:

$$\begin{array}{r} 0.1234 \\ + 0.4322 \\ + 1.5575 \\ - 0.3322 \\ \hline 1.7809 \end{array}$$

Enter	Depress	Print
	SET UP	
	+	***** +
	*	0.0000 *
1234	+	0.1234 * +
4322	+	0.4322 +
15575	+	1.5575 +
3322	-	0.3322 -
	*	1.7809 *
	SET UP	
	+	***** +

Date/Time Clock Functionality

Addressable – Set Up, #/Date

II* Change Sign	I* Date/Time Stamp
II♦ End	I♦ M ↔ Dec
II- Start	I- Days
II+ Compute	I+ HH.MM

Date/Time Clock Functionality is addressable after depression of the Set Up key followed by a depression of the #/Date key. Enabling this feature changes the operation of Memory I and Memory II to the alternative functionality identified above and described below:

Set or Change the Date and Time

Example: December 1, 2002 – 8:30am

Enter	Press	Display	Print
12.01.2002.8.30	Date/Time Stamp	12.01.2002 8.30	12 01 2002 8 30

When printed, date and time print on the same line, date formatted and left justified and time formatted and right justified. The line prints in red.

If, in the above example the time was 8:30pm, the following sequence of key depressions would be used.

Enter	Press	Display	Print
12.01.2002.8.30	Change Sign	12.012002830	
	Date/Time Stamp	12.01.2002 8.30	12 01 2002 8 30 P

When entering time, a positive value assumes the entry to be AM, while a negative value assumes PM. This convention eliminates the necessity of using military time.

Print/Display Date and Time

Enter	Press	Display	Print
No Live Entry Exists	Date/Time Stamp	12.01.2002 8.30	12 01 2002 8 30

Convert Minutes to Decimal Equivalent

Enter	Press	Display	Print
8.30	HH.MM	8 30	8 30
	M ↔ Dec	8.50	8.50

Convert Decimal to HH.MM Equivalent

Enter	Press	Display	Print
8.50		8.50	
	M ↔ Dec	8 30	8 30

Compute Hours Worked

Example: An employee starts work at 8:30am, takes a 45 minute break for lunch at 12:00, a 15 minute coffee break at 3:00pm and leaves work at 5:00pm. Determine how many hours this employee worked.

Enter	Press	Display	Print
8.30	Start	8 30	8 30
12.00	Change Sign	-	12.00
	End	12 00	12 00 P
12.45	Change Sign	-	12.45
	Start	-	12.45
		12.45	12 45 P
3.00	Change Sign	-	3.00
	End	-	3.00
		3.00	3 00 P
3.15	Change Sign	-	3.15
	Start	-	3.15
		3.15	3 15 P
5.00	Change Sign	-	5.00
	End	-	5.00
		5.00	5 00 P
	Compute	7.30	7.30

This employee worked 7 hours and 30 minutes. If you wish to convert the 7 hours and 30 minutes to the decimal equivalent to enable multiplying it by an hourly rate, perform the following key depressions.

Enter	Press	Display	Print
	HH.MM	7 30	7 30
	M ↔ Dec	7.50	7.50

The alternate method of computing the number of hours worked in the above example would be to use the adding machine in conjunction with the special function keys.

Enter	Press	Display	Print
8.30	Start	8 30	8 30
5.00	Change Sign	-	5.00
	End	-	5.00
	Compute	8.30	8.30
	+	8.30	8.30*+
.45	-	.45	.45 -
.15	-	.15	.15 -
	*	7.30	7.30 *
	HH.MM	7 30	7 30
	M ↔ Dec	7.50	7.50

Days between Dates

Example: Compute the number of days between December 3 and December 7. The number of days in this example will be four. The count includes Dec 3,4,5 & 6.

Enter	Press	Display	Print
12.03.2001	Start	12 03 2001	12 03 2001
12.07.2001	End	12 07 2001	12 07 2001
	Compute	4.00	4.00

Compute a Future Date

Example: Determine the date 4 days hence (December 3, 2001).

Enter	Press	Display	Print
12.03.2001	Start	12 03 2001	12 03 2001
4	Days	4.00	4.00
	Compute	12 07 2001	12 07 2001

Compute a Past Date

Example: Determine the date 4 days prior (December 7, 2001).

Enter	Press	Display	Print
12.07.2001	Start	12 07 2001	12 07 2001
4	Change Sign	- 4.00	
	Days	- 4.00	4.00
	Compute	12 03 2001	12 03 2001

Crossfooting, Percent Distribution and Proration Functionality

Addressable – Set Up, *

II* Cross Foot	I* Change Sign
II♦ Row	I♦ Column
II- % Distribution	I- Total
II+ Prorate	I+ Skip

Crossfooting, automatic percent distribution and automatic proration is addressable after depression of the Set Up key followed by a depression of the (*) Total key. Enabling this feature changes the operation of Memory I and Memory II to the alternative functionality identified above and described below.

The crossfooting function provides individual addressability of column and row locations. The term crossfooting refers to totaling across and down.

Example:

	C	O	L	U	M	N
		1	2	3	4	TOTAL
R	1	5	2	4	0	11
O	2	0	6	0	5	11
W	3	3	5	0	6	14
	4	6	0	4	7	17
	TOTAL	14	13	8	18	53

When the Crossfooting function is enabled through depression of the Set Up key followed by the Total (*) key, the plus and minus keys of the adding machine assign a value (positive or negative) to a column/row location. The function of total, when used, instructs Classic to move to the next column for entries. The orientation of this function is always from the perspective of column. In this example, depression of 5 followed by depression of +, places the value 5 in Column 1 Row 1. The value 0, in Column 1, Row 2, can be placed there by entering 0 and pressing plus, or by depressing the Skip key, which moves the pointer to the next location as Column 1 Row 3. The user could directly address a location by following a prescribed sequence. That sequence can be illustrated by the desire to place the value 3 in Column 1, Row 3. Enter 1, Press Column, Enter 3, Press Row, Enter 3, then press +. If a mistake is made in entry, correcting that mistake may be made by entering the correct amount, and following the sequence just described. Whatever value existed in that location previously will be replaced by the new value.

Crossfooting

When the Crossfoot key is pressed, the totals of all columns and rows will automatically print.

For the sake of brevity, only the printout will be presented below.

Enter	Press	Display	Print
	Crossfoot	
		1	C
			14.00
		2	C
			13.00
		3	C
			8.00
		4	C
			18.00
		
			53.00*C
		
		
		1	R
			11.00
		2	R
			11.00
		3	R
			14.00
		4	R
			17.00
		
			53.00*R
		

All values will remain in their assigned column and row locations. **They will not be automatically cleared!** In the event the user is moving to another crossfooting calculation, **and not to % Distribution or Proration**, the user must press **Crossfoot then C/CE**.

Using our example, let us assume that the user wants to perform a % Distribution. The % Distribution can be run on individual columns, individual rows, column totals or row totals. In the illustration below, we will first run a % Distribution on Column 1, then we will run a % Distribution on Row Totals.

% Distribution on Column 1, then Row Total

Enter	Press	Display	Print
	% Distribution		
	1		
	Column		
		
		1	%C
			35.71%
		1	%C
			0.00%
		1	%C
			21.43%
		1	%C
			42.86%
		
			100.00%
		
	% Distribution		
	Total		
	Row		
		
		1	%R
			20.75%
		2	%R
			20.75%
		3	%R
			26.42%
		4	%R
			32.08%
		
			100.00%
		

All values will remain in their assigned column and row locations. **They will not be automatically cleared!** In the event the user is moving to another crossfooting calculation and not to % Distribution or Proration, the user must press **Crossfoot then C/CE**.

Now let us assume that the purpose of all this functionality was to prorate a budget between departments. Again, proration may be performed against any column, row or the Total of Columns or Rows. Let us prorate a \$50,000 dollar budget proportionately against the Column Totals of our example.

Proration against Column Totals

Enter	Press	Display	Print
	50,000		
	Proration		
	Total		
	Column		
		
			1 PC
			13,207.55
			2 PC
			12,264.15
			3 PC
			7,547.17
			4 PC
			16,981.13
		
			50,000.00
		

Basic Financial Functionality

Addressable – Set Up, ♦

II* Change Sign	I* Amount
II♦ X x 12	I♦ Interest
II- X/12	I- # of Months
II+ Compute	I+ Payment

Basic financial functionality is addressable after depression of the Set Up key followed by a depression of the ♦ Subtotal key. Enabling this feature changes the operation of Memory I and Memory II to the alternative functionality identified above and described below:

The keys (Amount, Interest, # of Months and Payment) are designed to provide the user the ability to solve for Amount, # of Months, or Payment provided input has been made for Interest and two of the three other variables. Interest must be entered. User may not solve for Interest. **The amounts stored are not cleared once the missing variable has been computed. This enables the user to use some of the same variables to solve for different values. Compute followed by the C/CE key, clears all variables. Entering a new amount and pressing any of the four keys identified here, replaces the amount currently stored with the new amount.**

Example:

Loan Amount \$100,000, Interest 6.5%, Term 15 Years. Compute Payment

Enter	Press	Display	Print
	Set Up		
	♦		
100000	Amount	100,000.00	100,000.00**
6.5	Interest	6.50	6.50%I
15	X x 12	180.00	180.00
	# of Months	180.00	# 180.00
	Compute		
		
	Payment	871.11	871.11
		

Let us say the Payment amount is too high. Change the payment amount to \$600 and Compute # of Months.

Enter	Press	Display	Print
600	Payment	600.00	600.00
	Compute		
		
	# of Months	431	# 431
		
	X/12	35.917	35.917

In the above example, the number of months was calculated to be 431. To determine the number of years, the # of Months key was followed by the depression of the x/12 key.

Let us say we could pay a little more than the \$600 per month, if we could pay the loan off in a somewhat shorter period of time.

Enter	Press	Display	Print
360	# of Months	360.00	# 360.00
	Compute		
		
	Payment	632.07	632.07
		

To determine the amount one can afford to borrow, based upon a comfortable payment amount, term and interest rate, we could solve for Amount.

How much can I borrow, if I were able to afford \$1,000 per month, paying 6.5% Interest annually over a 15 year period?

Enter	Press	Display	Print
180	# of Months	180.00	# 180.00
1000	Payment	1,000.00	1,000.00
	Compute		
		
	Amount	114,796.41	114,796.41
		

For use on Monroe Classic Changing the Ribbon Cartridge

Use the Monroe P51M Ribbon

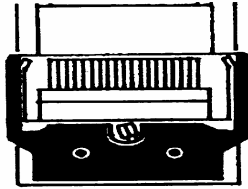

1. Remove excess paper tape.
2. Remove the printer cover. (Note how ribbon feeds, around guides and between print wheels and platen; black band up).

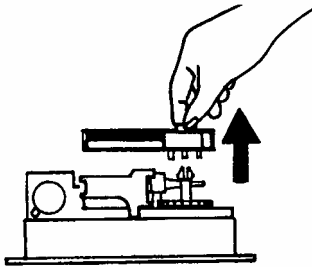

3. Lift out cartridge by moving the lever to the center; then move and lift out cartridge.
4. Holding new cartridge over spindles with black band up and exposed portion of ribbon on side nearest print wheels, place cartridge on spindle and engage cartridge...

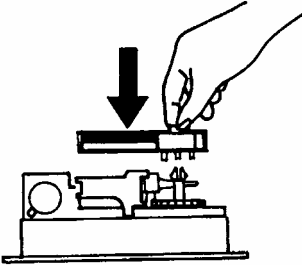

5. Replace printer cover.

For Use on Monroe Classic Changing the Ribbon

Use the Monroe P65M Ribbon

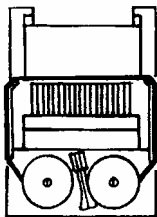

1. Remove excess paper tape.
2. Remove the printer cover. (Note how ribbon feeds from outside of spools, around guides and between print wheels and platen, black band up.)

3. Lift out spool that is not engaged by lever; then move lever aside and lift out other spool.
4. Hang new spools over spindles with black band up and exposed portion of ribbon on side nearest print wheels, place one spool on spindle not engaged by lever. Rotate spools to be sure its pins engage in spindle gear.
5. Thread ribbon around guides and between print wheels and platen.
6. Install other spool and rotate to engage spindle gear and also to take up slack in ribbon.
7. Replace printer cover.

Installing Paper Tape

To ensure ease of installation, read the instructions completely before installing a new paper roll. Then follow the instructions step-by-step.

1. Tear off excess paper at the tear-off knife.
2. To remove cover, place thumbs on serrated surfaces located on each side of the cover. Pressing down with your thumbs, slide the top cover toward the back of the calculator. Once the cover has been pushed back approximately 1", lift the cover off.

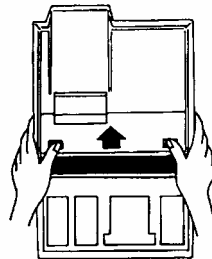

3. Lift up and remove old paper roll from the paper roll holders. Tear off paper between the used paper roll and the printer. Pull remaining paper through the printer by continuously lifting the leading edge (nearest display).

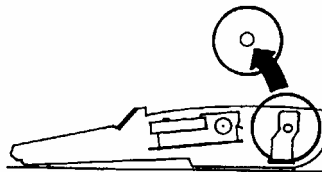

4. With the leading edge of the new paper roll, feeding from the bottom, place the new roll into position between the two flexible paper roll holders.



5. Feed the paper into the rear of the printer mechanism until it meets resistance (approximately 1 to 1.5 inches). Depress the paper advance button until the paper extends several inches beyond the printer mechanism.



6. Feed the paper through the opening of the tear-off knife and lay top cover flat on the calculator leaving a 1" overhang at the back of the top cover. Apply a firm downward and forward pressure, slide the top cover forward until it snaps into position.
7. Tear off any excess paper.

Spare Supplies Storage Compartment

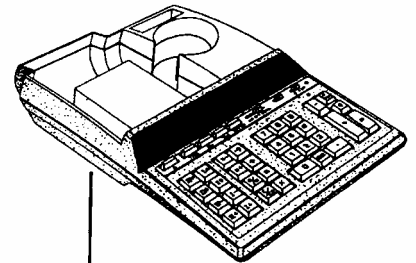

Extra ribbon cartridge storage

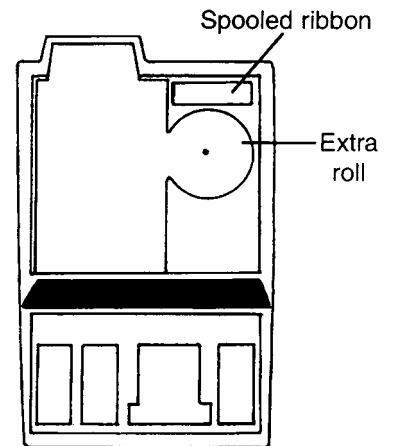

Spooled ribbon

Extra roll

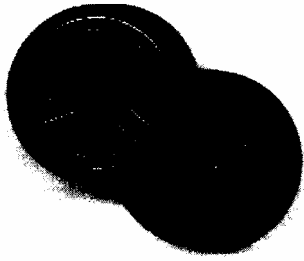

**The time to order
Monroe's Long Life
Replacement Ribbons is
before the ink is dry.**

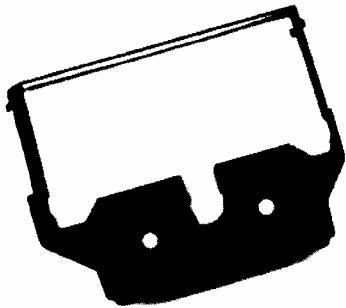

Congratulations...

Welcome to the Monroe family of office products. You've just made an intelligent purchase and a valuable investment. Now is the time to protect your investment. Don't wait until the ink is dry. Order the correct replacement ribbon today. Monroe Long Life Replacement Ribbons are designed for Monroe calculators and are reliable and economically priced. Individual packaging keeps your ribbon stock fresh. You can stock up on supplies to ensure never being caught without one on hand.

How to Order Supplies

For supply pricing information and ordering supplies for your new Monroe Classic calculator, just phone, fax or mail your request as follows:

To Phone: Dial 1-888-Monroe 1 (or 1-888-666-7631). (We accept Visa and MasterCard).

To Fax: Fax your order, with credit card information, to 877-666-7635. You must include the account number, name as it appears on your credit card and expiration date.

To Mail: Send your check or money order to:
Monroe Systems for Business
47 Runway Road, Suite G
Levittown, Pennsylvania 19057-4738

Web-site: <http://www.monroe-systems.com>

E-mail: csr@monroe-systems.com

Monroe Classic Calculator Supplies

<u>Description</u>	<u>Calculator Model</u>	<u>Item #</u>
Monroe Replacement Cartridge Ribbon	Monroe Classic	P51M
Monroe Replacement Spool Ribbon	Monroe Classic	P65M

In addition to the Classic, Monroe offers a complete line of supplies for all Monroe calculators and many competitive model calculators. If interested, please ask for a complete compatibility listing.

LIMITED WARRANTY

Monroe warrants to the original end user Customer that the equipment will, at the time of delivery to such Customer, be free from defects in manufacture. During the warranty claim period, which shall be 180 days from the date of original delivery to original end user Customer, Monroe will provide, based upon a verified claim under this Limited Warranty, adjustments, repairs, labor and parts to place the equipment in proper operating condition (or will provide a replacement at its sole option). This warranty does not cover supplies, consumable items, external accessories or damage resulting from accident, misuse, abuse, neglect, faulty installation, use contrary to specifications, combination with other equipment, acts of God, modification, or unauthorized repair or alteration. This Limited Warranty is valid only for equipment sold and installed in the continental United States, Alaska, and Hawaii.

THE FOREGOING SHALL BE THE SOLE AND EXCLUSIVE REMEDY WITH RESPECT TO THE EQUIPMENT. ANY CLAIM MUST BE MADE WITHIN THE APPLICABLE WARRANTY CLAIM PERIOD. THIS WARRANTY IS IN LIEU OF ALL OTHER WARRANTIES, EXPRESS, IMPLIED AND STATUTORY, INCLUDING, WITHOUT LIMITATION, ANY WARRANTY WITH RESPECT TO MERCHANTABILITY OR FITNESS FOR A PARTICULAR PURPOSE. THE WARRANTY CLAIM PERIOD SHALL NOT BE EXTENDED BY REASON OF A CLAIM UNDER THIS WARRANTY OR OTHERWISE. THE LIMITATIONS CONTAINED IN THIS WARRANTY ALSO APPLY TO ANY ADJUSTMENTS, REPAIRS, LABOR, PARTS AND/OR REPLACEMENTS UNDER THIS WARRANTY. MONROE SHALL NOT BE LIABLE FOR CONSEQUENTIAL, INCIDENTAL, INDIRECT, SPECIAL OR PUNITIVE DAMAGES OR FOR LOSS OF PROFITS OR OTHER ECONOMIC LOSSES OR OTHER LOSSES ARISING OUT OF OR RELATED TO EQUIPMENT WHETHER SUCH DAMAGES BE DIRECT, INDIRECT, FORESEEABLE OR OTHERWISE AND WHETHER LIABILITY IS CLAIMED TO ARISE BY REASON OF CONTRACT, TORT, STRICT LIABILITY, NEGLIGENCE, OR OTHER LEGAL THEORY. THERE DOES NOT EXIST, NOR IS ANYONE AUTHORIZED TO MAKE, ANY PROMISES, WARRANTIES OR REPRESENTATIONS NOT CONTAINED IN THIS LIMITED WARRANTY. IN NO EVENT SHALL MONROE'S LIABILITY EXCEED THE PRICE OF THE PARTICULAR PIECE OF EQUIPMENT IN QUESTION.

THE MATERIAL CONTAINED HEREIN IS SUPPLIED WITHOUT REPRESENTATION OR WARRANTY OF ANY KIND BY MONROE SYSTEMS FOR BUSINESS, INC. MONROE ASSUMES NO RESPONSIBILITY RELATIVE TO THE USE OF THIS MATERIAL AND SHALL HAVE NO LIABILITY FOR ANY DAMAGES, WHETHER DIRECT, INDIRECT, CONSEQUENTIAL, OR OTHERWISE ARISING FROM THE USE OF THIS MATERIAL OR ANY PART THEREOF.

TO MAKE A CLAIM UNDER THIS LIMITED WARRANTY, THE EQUIPMENT MUST BE SHIPPED, INSURED AND PREPAID TO THE MONROE FACTORY SERVICE CENTER TOGETHER WITH PROOF OF PURCHASE (PURCHASE RECEIPT, INVOICE OR OTHER ACCEPTABLE EVIDENCE OF TIME AND PLACE OF PURCHASE). MONROE WILL PAY RETURN SHIPPING CHARGES TO CUSTOMER FOR VERIFIED LIMITED WARRANTY CLAIMS ONLY. MONROE WILL NOT BE RESPONSIBLE FOR SHIPPING DAMAGE OR LOSS.

**Monroe Factory Service Center
Monroe Systems for Business, Inc. - Warranty Department
47 Runway Road, Suite G
Levittown, Pennsylvania 19057-4738**



"The Calculator Company"

**47 Runway Road, Suite G
Levittown, Pennsylvania 19057-4738**

Telephone: 888-666-7631 or 267-580-2600

Facsimile: 877-666-7635 or 267-580-2645

E-mail: csr@monroe-systems.com

Web Site: <http://www.monroe-systems.com>

© 2002. Monroe Systems for Business. All rights reserved. Monroe, Monroe Systems for Business, the "M-Star" logo are registered trademarks of Monroe Systems for Business.