

A02™

THINK
OUTSIDE
THE
CUBE...



WHERE
DESIGN
MEETS
PERFORMANCE.



THINK





The A02 panel systems line is a true performer. With a broad selection of panel sizes and styles, worksurfaces, storage options and complementing accessories, A02 is a complete and versatile panel system.

Shipped fully assembled and ready to install, panels and components are easily reconfigured to meet your changing workspace requirements.

Take the AIS challenge.
Up to 300 workstations
shipped in 10 working days.
We dare you.

AO2 is a panel system with classic style and classic capability.

Featuring enhanced power and data capacities, virtually limitless worksurfaces, components, and panel options – AO2 is the ideal combination of performance and value.

SAY GOODBYE TO POOR SELECTION.
AIS OFFERS FOURTEEN DIFFERENT STANDARD
PANEL SIZES, GLASS, DOORS,
LAMINATES AND CUSTOM PANEL OPTIONS.
THE CHOICE IS YOURS.

Innovative panel and component options combined with compatible connectivity to OEM products make AO2 a unique and diversified product solution.



AND AFFORDABLE.

THINK 



Achieve maximum space planning flexibility with our complementing components and virtually limitless worksurface options. With AO2, your office will project a solid, professional image.

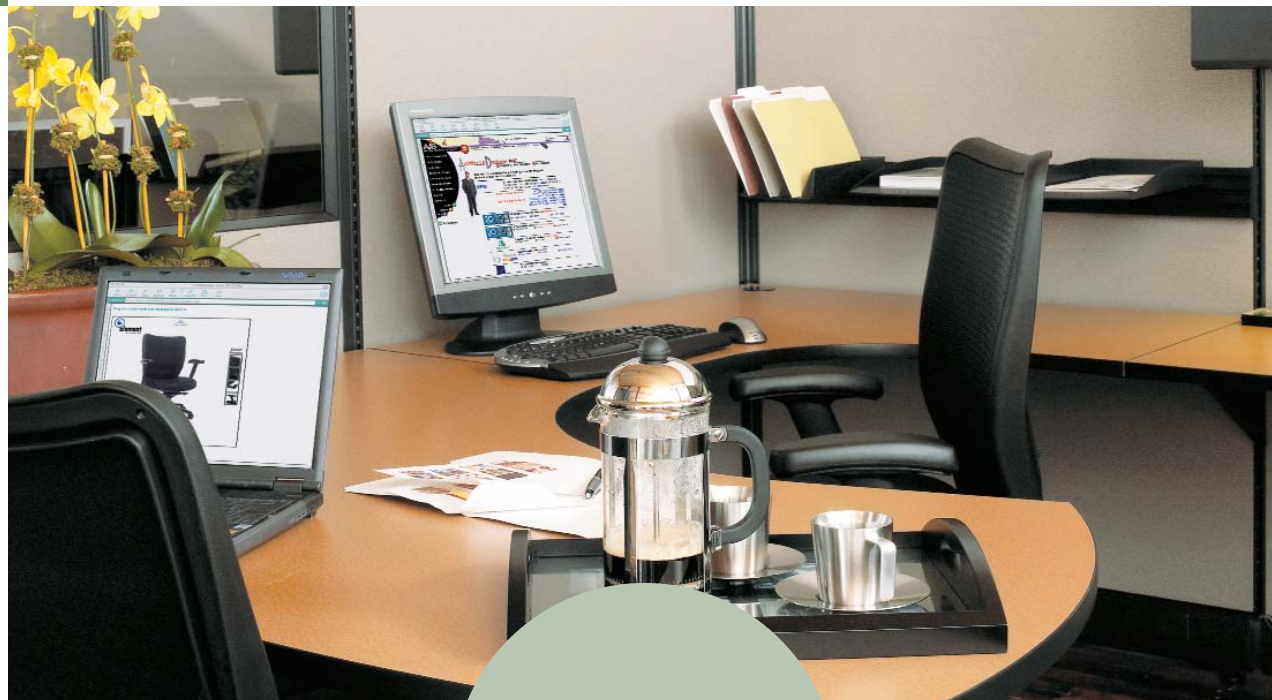

A DESIGNER'S DREAM.
OVER 400 FABRICS AND 150 LAMINATE OPTIONS.
ENDLESS POSSIBILITIES.

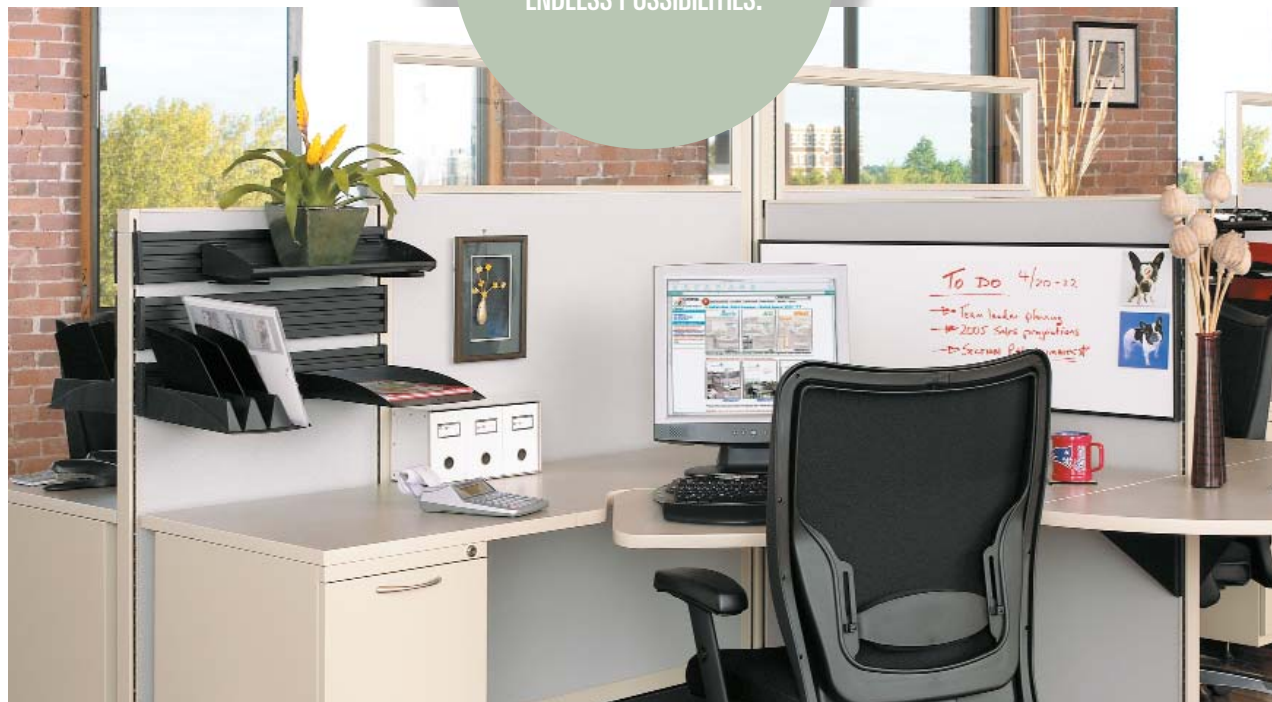

The office you've dreamed of in 10 working days – AIS guarantees it. With Quick Ship, AIS offers AO2 panels available in 14 heights and widths, 10 paint finishes, and 120 Grade A fabrics.

AIS offers an extensive palette of panel fabrics, laminates and paint finishes, providing both value and design options.



CUSTOM SIZES.
36 STANDARD WORKSURFACE SHAPES AND 7 PANEL STYLES.
JUST THE WAY YOU WANT IT.



Locking overhead storage and complementing half- or full-height shelf units are available to accommodate different storage requirements.



HAS NEVER BEEN EASIER.

THINK 



AO2 is a proven furniture systems workhorse. Manufactured with exceptional quality standards and practices, AO2 means reliability.



COMPATIBLE.
 WITH REAL ACTION OFFICE® FROM HERMAN MILLER®.
 INTEGRATE, RECONFIGURE, REVAMP*.



On GSA schedule, group 71, AO2 provides a competitive and versatile solution for federal government agencies. GSA schedule pricing includes AIS Quick Ship programs at no additional cost, providing federal buyers many affordable choices.



AO2 is built for life. Backed by the AIS lifetime warranty, we stand behind our products. AO2 systems meet and exceed ANSI/BIFMA standards.



LIFETIME WARRANTY.

AIS GUARANTEES YOUR AO2 WORKSTATION WILL BE FREE FROM MANUFACTURING DEFECTS.

YOU HAVE OUR WORD.



AO2 is a proven performer. With one of the most simple, yet sturdy panel connection designs in the market, AO2 bridges performance and practicality.

Durable all-metal panel end caps withstand heavy-duty wear and tear.

ELECTRIFY...

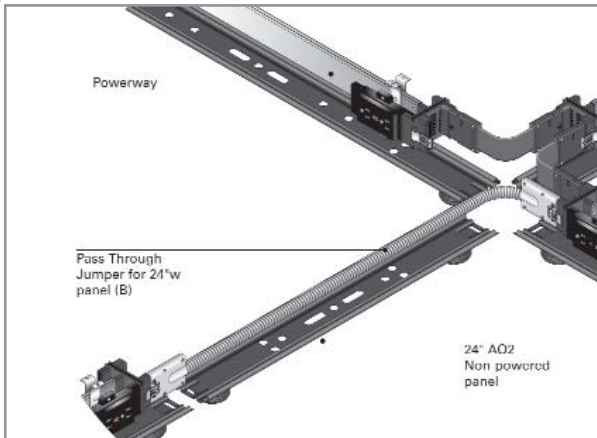

AO2 electrical, 8-wire, 4-circuit 3-way 90-degree connector. Used to connect 3 adjacent powered panels of any width at 90-degrees.

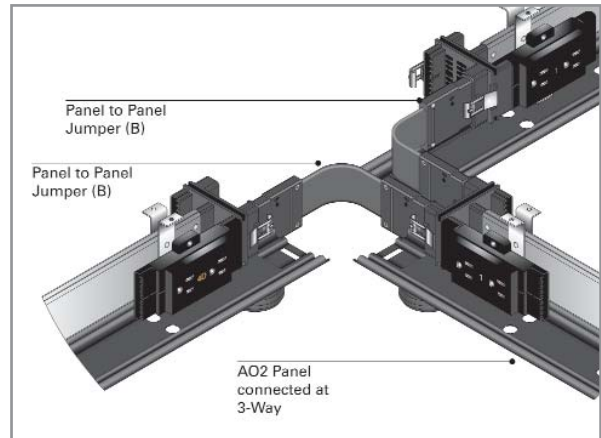

AO2 electrical, 8-wire, 4-circuit 3-way 90-degree connector. Used to connect 3 adjacent powered panels of any width at 90-degrees.

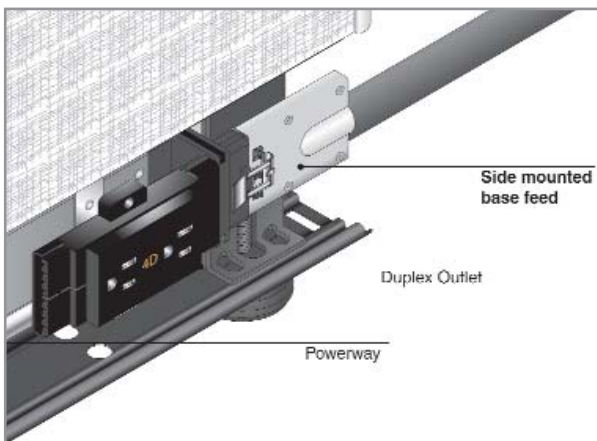

AO2 electrical 8-wire, 4-circuit side mounted base feed. Used to connect building power supply to the base of the wall or floor monument.

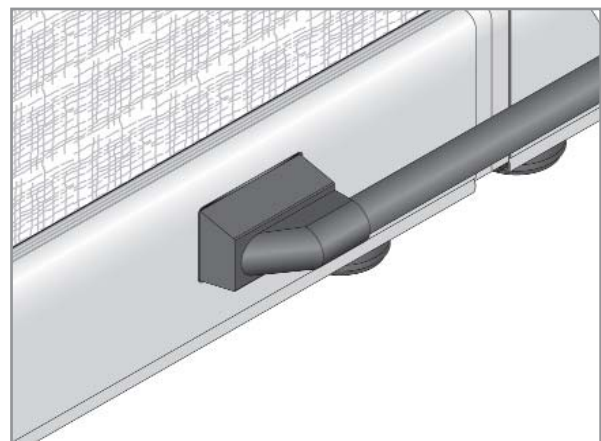

AO2 electrical, 8-wire, 4-circuit receptacle mounted base feed. Connects building power supply at the base of the wall or floor monument.



The enhanced power and data capacity of the AO2 panel raceway meets the challenge of today's technically demanding work environments.

AO2 offers lay-in power and data capacity for easy installation with high capacity for up to 100 pair Category 5 or Category 6 cables in a non-powered raceway.

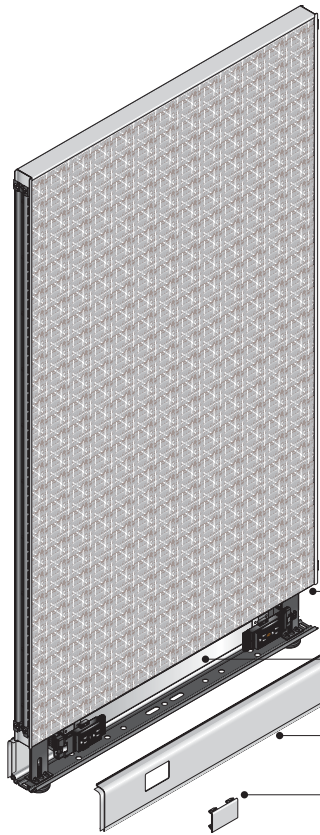

- **Compatible with HM Electrical**
- **80 Amps/ 4 Circuits per Base Feed**
- **10 Gauge Neutrals**
- **Dedicated/Isolated Circuit**

Raceway cavity - Provides for data and electrical distribution.

Powerway - provides electrical distribution and access for up to four duplex outlets front and rear.

Powered Base Covers - are removable and are punched out to provide access to duplex outlets.

Duplex Hole Covers - cover unused duplex outlet locations.

CROSS SECTION 8 WIRE 4 CIRCUIT CABLE

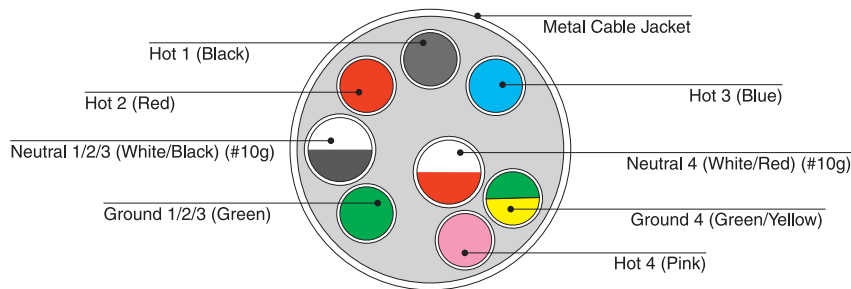

OEM Compatibility - AIS AO2 system is compatible with older OEM electrical systems. Please consult your AIS representative to identify the best solution for your particular application.

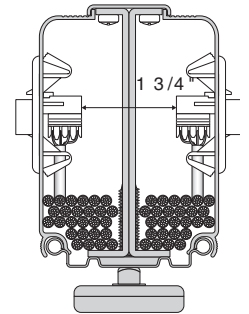

AO2 Non-Powered Panel Wiring Schematic

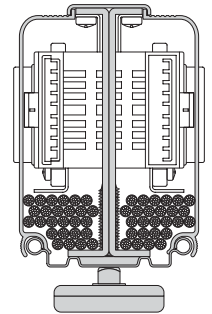

AO2 Powered Panel Wiring Schematic



Panel raceways provide high capacity for concealed data and power.



Closed AO2 panel raceway.



Grommets provide power access in a clean aesthetically pleasing manner.

Maximize your storage capacity with flipper doors, shelves, and pedestals. Pedestals are offered in a variety of configurations.



STORAGE.
 MAXIMIZE YOUR STORAGE CAPACITY WITH SENSIBLE SOLUTIONS.
 AIS ACCOMMODATES EVERY NEED.



AIS offers flipper doors painted, fabric-covered, and laminated to suit your style. Flipper door units are the perfect storage solution, keeping workstations neat and clean.

Easily integrate tool rails with the AO2 system. Choose from a variety of paper management tools, shelves, pencil trays, folder sorters and more.



ACCESSORIZE. COMPLEMENT.
 AIS OFFERS A MULTITUDE OF ACCESSORY OPTIONS.
 MAXIMIZE YOUR WORKSPACE.



Whiteboards in 12 different sizes can be integrated into any AO2 workspace. Keyboard trays can also be mounted to any worksurface for advanced ergonomics.

PANELS AND WORKSURFACES.

PANELS

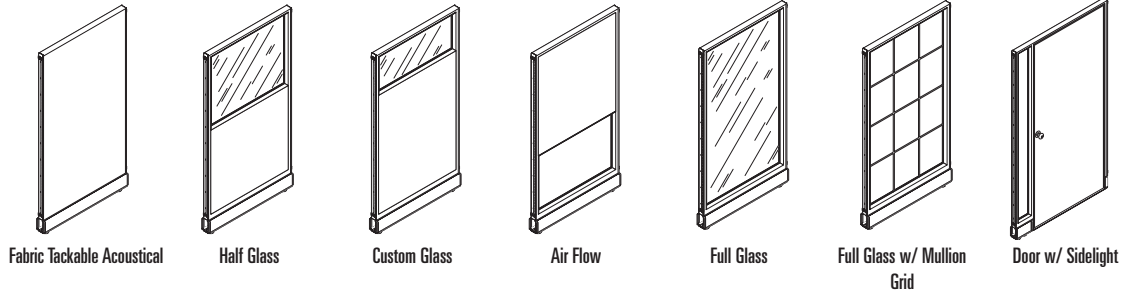

WORKSURFACES

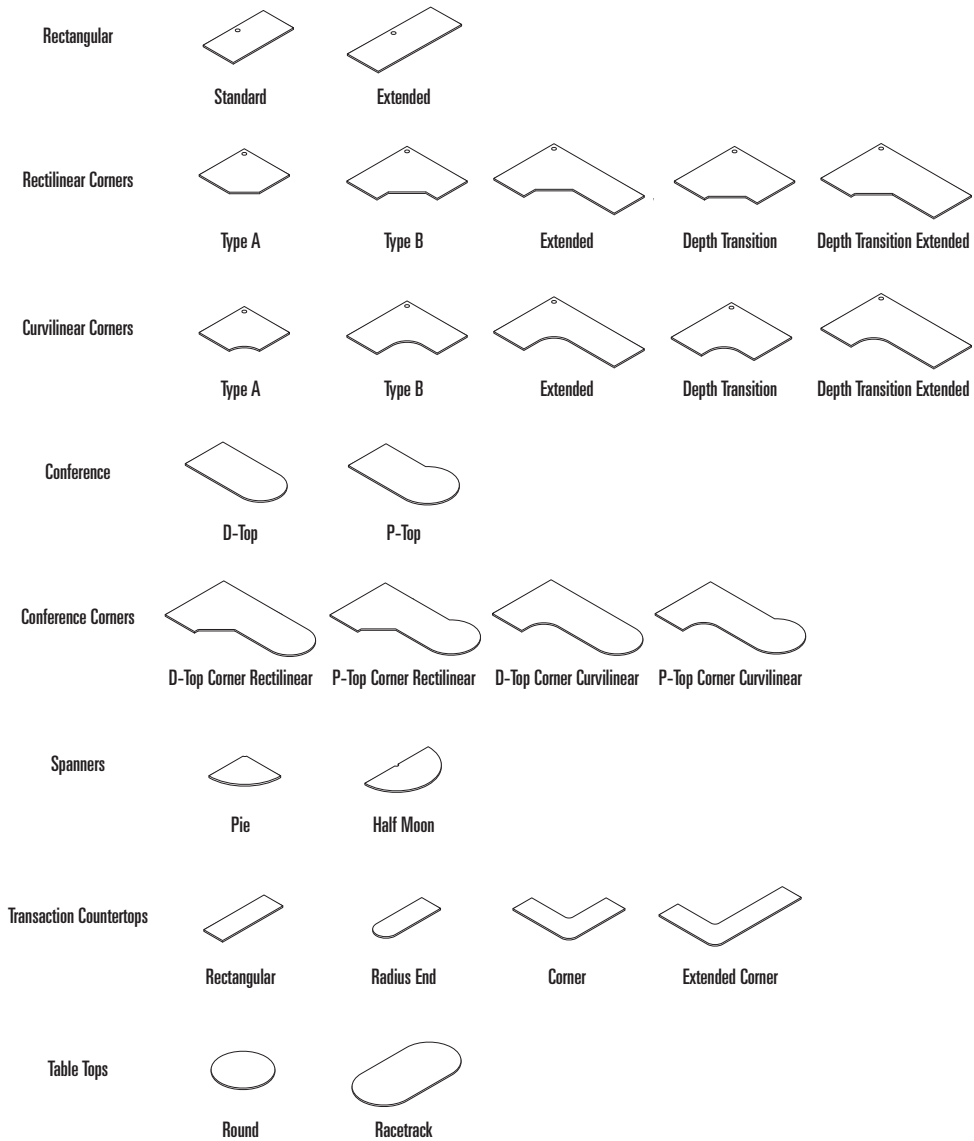

STORAGE AND ACCESSORIES.



Specialty



Cockpit Corners

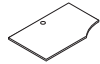

Cockpit Returns



Quarter Rounds



Half Rounds



Three Quarter Rounds



Sweep Conference



Crescent Conference



Flair Ends



Rectangular Radius End



Fin

STORAGE

Pedestals

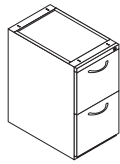

Structural File/File 24"

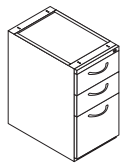

Structural Box/Box/File 24"

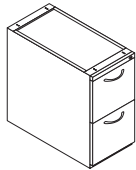

Structural File/File 30"

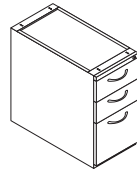

Structural Box/Box/File 30"



Mobile Box/File 20"



Mobile w/ Seat Box/File 20"

Bookcases 2-Door Cabinets Lateral Files

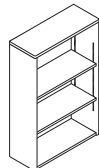

Bookcase

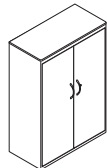

2-Door Storage Cabinet

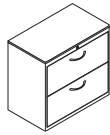

2-Drawer Lateral File



3-Drawer Lateral File

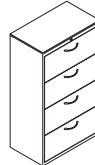

4-Drawer Lateral File

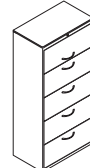

5-Drawer Lateral File

Wardrobe Storage Towers

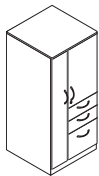

50" Storage Tower Box/Box/File

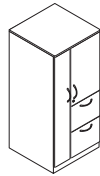

50" Storage Tower File/File

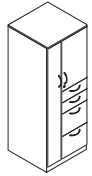

62" Storage Tower Box/Box/File/File

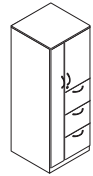

62" Storage Tower File/File/File

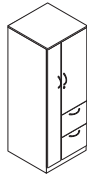

62" Storage Tower File/File

Panel Hung Overheads

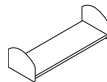

Mid-Height Shelf Unit

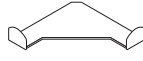

Mid-Height Corner Shelf

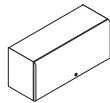

Type C Flipper Unit

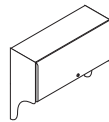

Type C Raised Flipper Unit

ACCESSORIES



Tasklights

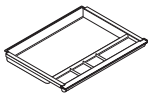

Pencil Drawer

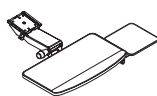

Keyboard Arm

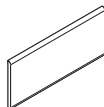

Tackboards

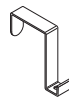

Coat Hooks



Cord Managers

When it comes to implementing lean manufacturing into production processes, AIS has been an industry pioneer – eliminating waste every step of the way. In fact, AIS was awarded the prestigious Shingo Award in 2003 for Excellence in Lean Manufacturing.

LEAN AND GREEN.
**AIS HAS BEEN A PIONEER IN LEAN
MANUFACTURING FOR THE ENTIRE SYSTEMS
FURNITURE INDUSTRY.**
A WINNING COMBINATION.

Strongly committed to waste elimination, tied with environmentally sustainable manufacturing practices, AIS understands that today's actions affect our future.



AIS is committed to the production of high-quality durable products that conserve environmental resources.

Every day AIS moves closer to becoming a sustainable company. In its production processes, AIS recaptures powder paint for its powder coating, integrates 71% recycled materials into its systems and eliminates waste in its packaging.

Currently, AIS is pursuing various environmental certifications to further exercise the outcome of its Green initiatives.

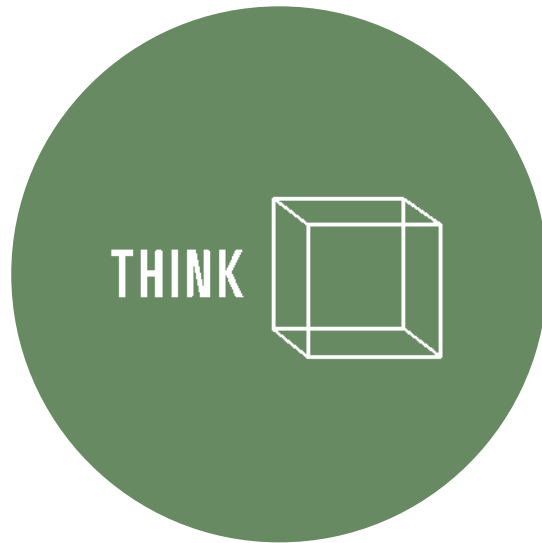

GSA Sales
GSA Contract GS-29F-0006K
FSC Group 71, Part I Office Furniture

For additional information on AIS:

Dealer Showrooms
Representative Directory
Project Case Studies
Online Catalog & Product Showcase
Visit: www.ais-inc.com



4 Bonazzoli Avenue - Hudson, MA 01749
800-434-7400 - 978-562-7500 - Fx 978-562-0811
www.ais-inc.com



2003 Shingo Prize Winner
Excellence in Manufacturing
www.shingoprize.org